

705 Series Air Operated Vacuums 15, 30, & 55 Gallon Units

Model:
C70515-01
C70515-02
C70530-01
C70555-01

OPERATION

SERVICE

PARTS

CARE

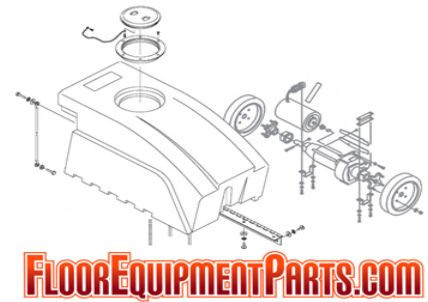
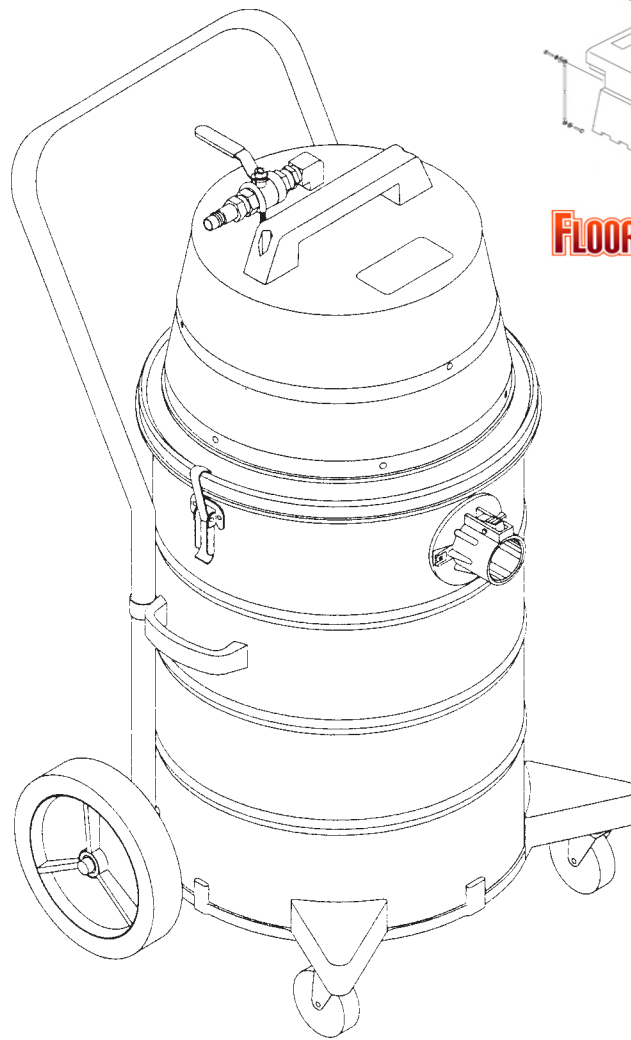

Revised 7/02

Minuteman[®]

**MODEL 705 AIR OPERATED
WET/DRY RECOVERY VACUUMS**

OPERATING INSTRUCTIONS

INSPECTION

Carefully unpack and inspect your machine for shipping damage. Each unit is tested and thoroughly inspected before shipment, and any damage is the responsibility of the delivering carrier who should be notified. Read all instructions carefully before operating.

SPECIAL WARNING

Air operated equipment can generate static electricity during use. Static dissipating arcing can be generated and occur if equipment and accessories are not grounded. Risk of explosion is possible if operated near explosive materials or vapors. Do not operate this equipment near flammable materials such as solvents, thinners, fuels, grain dust, etc.

AIR PRESSURE AND C.F.M. VOLUME REQUIRED

For maximum performance, operate with 1/2" air pressure line, 80 PSI (max. 100 PSI) and 42 input C.F.M. Air pressure control valve can be regulated to operate with lower pressure and C.F.M. when maximum is not required.

MAINTENANCE AND USAGE

Air supplied to vacuum must be clean and dry to avoid contamination and to maintain optimum performance.

Empty tank, clean filter bag and replace disposable filters regularly. Clogged filters restrict air flow and results in reduced vacuum performance.

Always shut off main air supply and open air valve at vacuum to relieve pressure before disconnecting air pressure line.

**ASSEMBLY PROCEDURE FOR MODEL C70515-01 AND C70515-02
WET/DRY RECOVERY VACUUMS
(See schematic on page 10, figure 1)**

1. For dry recovery, place filter bag assembly #2 onto tank assembly #4.
2. Place lid assembly #1 onto tank and fasten lid latches.
3. Connect 1/2" air pressure line to shut off valve on lid.
4. Attach vacuum hose to intake. Vacuum intake will accept 1 1/2" and/or 2" hose.
5. To operate, open air shut off valve to desired setting. OPTION: For fine dust recovery, a filter bag protector #3 is recommended to be installed ahead of the filter bag assembly #2. (Must be ordered as separate item #805038PKG of 12.)

CLEANUP PROCEDURE

For wet recovery remove filter bag #2 and filter protector #3 if used. Ball float within cage will activate at 12 gallon recovery level.

Always empty and dry tank assembly at end of each operating day or when vacuum will not be in use over extended period of time.

1. Shut off air supply at lid assembly.
2. Loosen lid latch and remove lid assembly.
3. Remove cloth filter bag assembly.
4. When filter bag protector is used, remove protector.
5. Empty tank into suitable trash container.
6. Reassemble following above procedure.

ASSEMBLY PROCEDURE FOR MODEL C70530-01 AND C70555-01
WET/DRY RECOVERY VACUUMS
(See schematic on page 10, figure 2)

1. For dry recovery, place heavy duty plastic bag liner, no. 6, into drum and drape over rim of drum no. 7 (without bag liner all debris you pick up will go directly into the drum).
2. Place adapter ring no. 5 onto drum.
3. Place filter bag assembly no. 2 onto adapter ring. Option: for fine dust recovery, a filter bag protector no. 3 is recommended to be installed ahead of the filter bag assembly. When installing the filter bag protector, insert it into the adapter ring and drape the elastic over the rim of the adapter to hold it in place. (Filter bag protectors must be ordered as separate item #805038, package of 12.)
4. Place air vacuum lid assembly no. 1 onto adapter and fasten lid latches.
5. Connect 1/2" air pressure line to shut off valve on lid.
6. Attach vacuum hose to intake vacuum, intake will accept 1 1/2" and/or 2" hose.
7. To operate, open air shut off valve to desired setting. When recovering fine dust open air valve to 1/2 opening to avoid filter from overloading prematurely. Increase air supply gradually as vacuum performance may decrease.

CLEANUP PROCEDURE

For wet recovery place adapter onto drum, remove filter bag and filter protector. Place the vacuum lid assembly onto adapter on drum without filters.

1. Shut off air supply at lid assembly.
2. Loosen lid latches and remove lid assembly.
3. Remove cloth filter bag assembly.
4. When filter bag protector is used, remove protector and place in drum or bag liner with debris.
5. Remove adapter ring.
6. If bag liner is used, gather liner at the top, tie the bag liner, place drum on its side and slide out bag liner with debris.
7. If bag liner is not used, empty drum into suitable trash container.

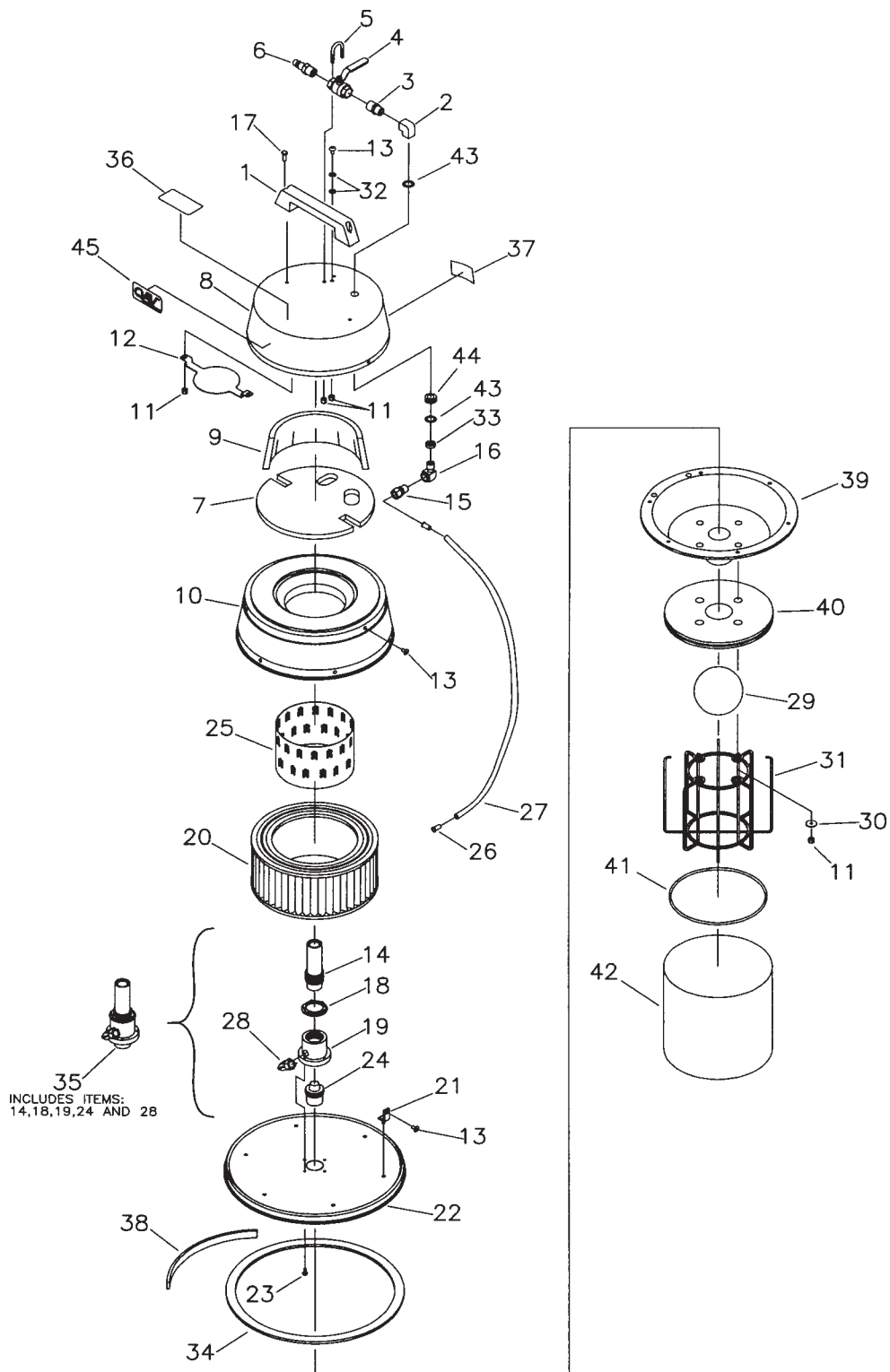

Parts List

Item No.	Part No.	Qty.	Description
1	460000	1	Handle
2	700028	1	3/8 X 3/8 Brass Elbow
3	420017	1	Hew Nipple Reducer
4	701009	1	.50 Valve
5	712105	1	U-Bolt
6	701010	1	.50 Coupler
7	700018	1	Dome Felt
8	700022PTD	1	Top Cover
9	700016	1	Felt Liner
10	700023PTD	1	Filter Cover
11	712667	15	1/4-20 SS Nyloc Nut
12	700019	1	Air Deflector
13	710178	10	1/4-20 x .50 SCR-MC STPL
14	700012	1	Venturi Exhaust Tube
15	420008	1	Male Connector
16	830062	1	3/8 x 3/8 Brass ST90
17	713002	2	BLT HH 1/4-20 x .75 #5
18	700014	1	Locking Nut
19	700011	1	Venturi Housing
20	700026	1	Exhaust Filter
21	832106	6	Bracket Mounting Tab
22	700024	1	Bottom Pan
23	712536	4	SCR-THMC 10-24 x .62 STPL
24	700013	1	Venturi Intake
25	700017	1	Perforated Shield
26	420011	2	Brass Insert
27	700021	1	Poly Hose 32" Long
28	420009	1	Male Elbow 469F
29	380046	1	Hollow Rubber Ball
30	712761	4	WSR-FLat .25x1.01x.06 SS
31	380045CTD	1	Float Cage Assembly
32	711505	2	WSR-Flat 1/4
33	829285PLT	1	Spacer-Zinc Plated
34	480052	1	Gasket, Rubber .25x.87x.50
35	700010	1	Venturi Assembly
36	715003	1	Decal, Air Pressure
37	715029	1	Decal, Serial Name Plate
38	480053	1	Rubber Locating Ring
39	750801	1	Water Shut-Off Adapter
40	760231MCH	1	Adapter
41	760260	1	Spring
42	760234	1	Lint Filter Bag
43	711513	2	WSR-Flat .689x1.06x.029 SS
44	260274	1	Grommet
45	715388	1	Decal, QAV

15 Gallon Painted/Stainledd Steel Tank with Molded Intake

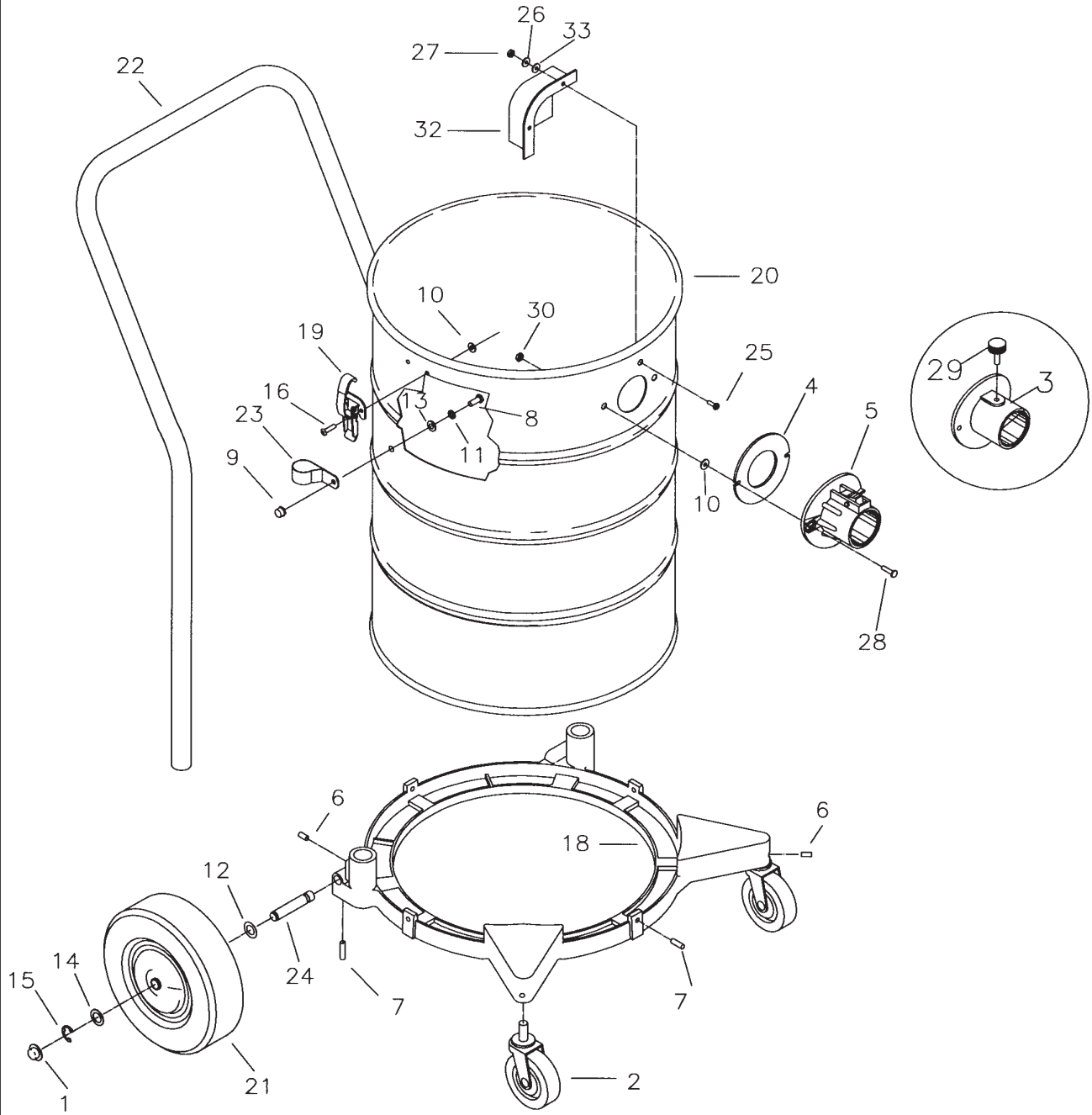

Parts List

Item No.	Part No.	Qty.	Description
1	130032	2	Cap, Retainer
2	280016	2	Caster 3"
3	900112	1	Intake, MCH (750381-2 Only)
4	390087	1	Gasket Diecut
5	390110	1	Intake Assembly Aluminum
6	711005	4	SCR-SK 1/4-20 x .31
7	711006	6	SCR-SK 1/4-20 x .62
8	711202	2	BLT-HH 1/4-20 x .50 STPL
9	711352	2	Nut-Acorn 1/4-20 ST NI
10	711503	8	WSR-Flat #10
11	711505	2	WSR-Flat 1/4
12	711524	2	WSR-Wave .52 x .87 x .01
13	711591	4	WSR-Rubber
14	711594	2	WSR-Flat .56 x .88 x .03 NI
15	711713	2	Retaining Ring Ext .50
16	711915	6	Rivet-Tube .19 x .28 NI PL
18	760984PTD	1	Bracket, Wheel
19	761054	2	Latch
20	900001PTD	1	Tank 15G Painted
21	900008	2	Wheel 8.00 Dia
22	900037PLT	1	Handle, Plated
23	900038	2	Clamp, Handle
24	900066	2	Axle
25	710530	1	SCR-MC 8-32x.50 BR
26	711502	1	WSR-Flat #8
27	711372	1	Nut-Nloc 8-32 (750382 Only)
27A	711304	1	Nut-Hex 8-32 (750381-2 Only)
28	712824	2	SCR-THMS 10-24x.75 STPL
29	500033	1	Locking Screw (750381-2 Only)
30	712638	2	Nut Hex 10/24 SS Nyloc
32	900035	1	Deflector, Intake
33	711542	1	Helical Washer #8
***	750381	1	TK Asy 15 Gal PTD Hi/Intake
***	750381-1	1	TK Asy 15 Gal PTD Hi/Intake
***	750381-2	1	TK Asy 15 Gal PTD Hi Amr Vac

Drum Adapter

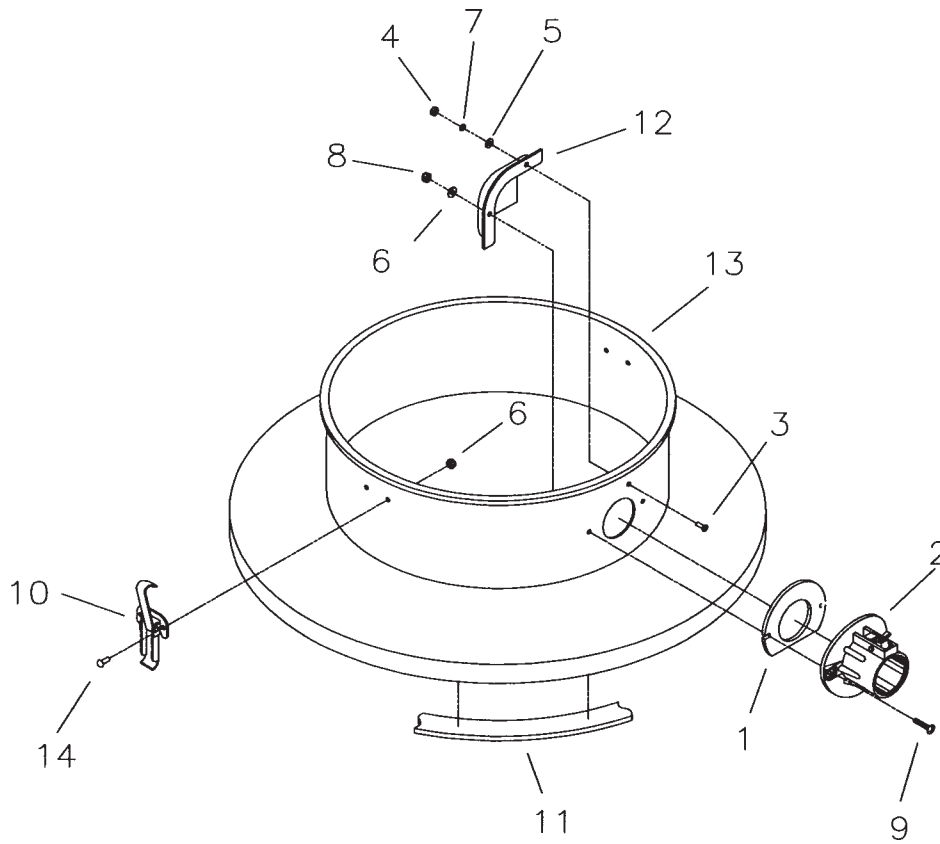

Parts List

Item No.	Part No.	Qty.	Description
1	390087	1	Gasket Diecut VNN
2	390110	1	Intake Asy Aluminum
3	710530	1	SCR-MC 8-32x.50 BR
4	711304	1	Hex-Nut 8-32 ST PL
5	711502	1	Flat Washer #8
6	711503	6	Flat Washer #10
7	711542	1	Helical Washer #8
8	712638	2	Nut Hex 10/24 SS Nyloc
9	712824	2	SCR-THMS 10-24x.75 STPL
10	761054	2	Latch
11	806006	1	Gasket
12	900035	1	Deflector, Intake
13	806015PTD	1	30 Gal Adapter Painted
13A	806016PTD	1	55 Gal Adapter Painted
14	711915	4	Rivet Tube
***	C80601-70	1	30 Gal Adapter Asy
***	C80601-80	1	55 Gal Adapter Asy

Drum Assembly

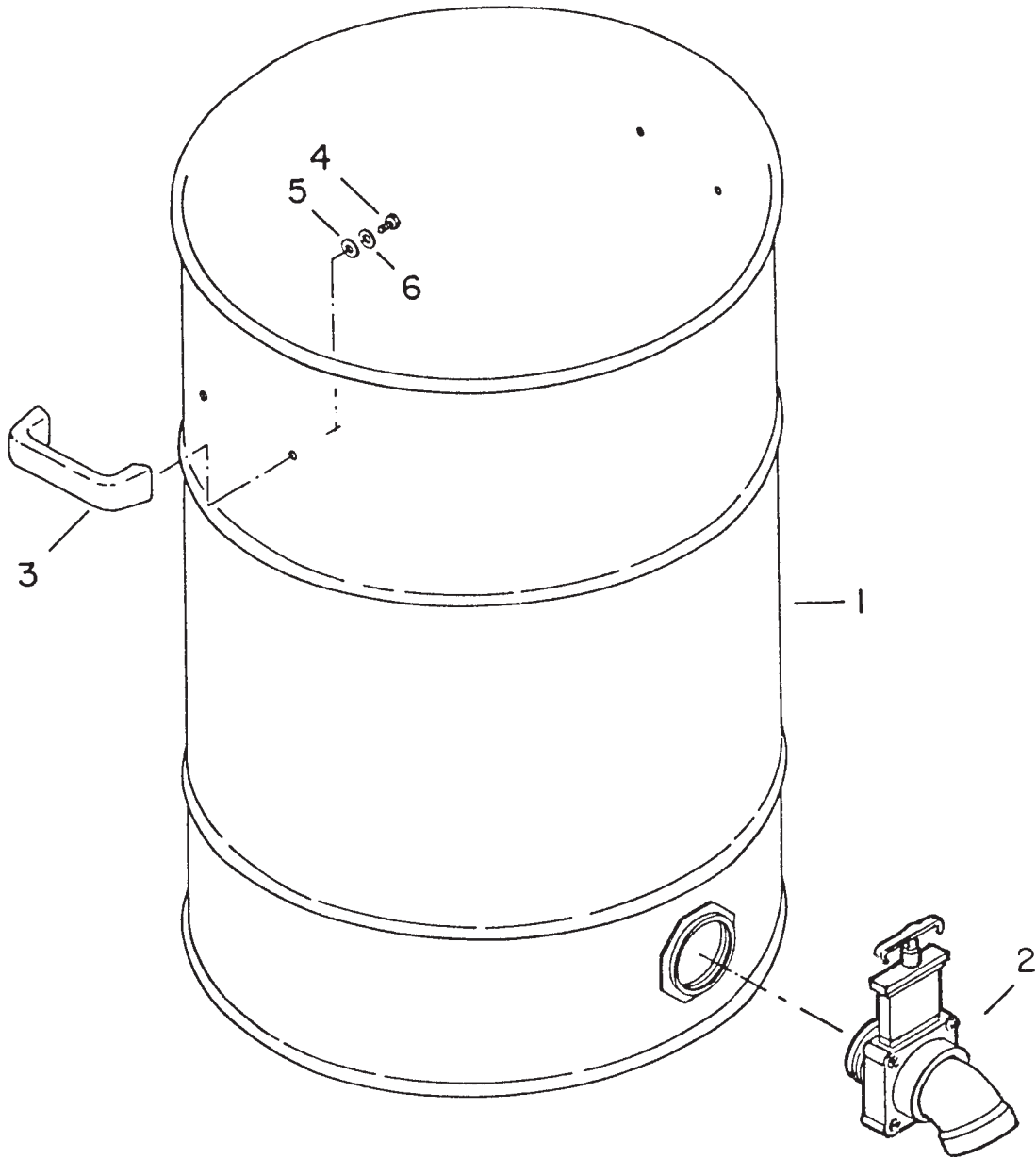

Parts List

Item No.	Part No.	Qty.	Description
1	900078PTD	1	Tank 30 Gal PTD Less Handles
1A	900015PTD	1	Tank 55 Gal PTD No Handles
2	900047	1	Dump Valve
3	900031POL	2	Handle, Tank Polished
4	711203	4	BLT, HH 1/4-20 x .62
5	711591	4	Washer, Rubber
6	711505	4	WSR, Flat 1/4
***	C90007-80	1	Tank 30 Gal Complete
***	805037PKG	1	Drum Liner 30 Gal Pkg 12
***	805046PKG	1	Drum Liner 55 Gal Pkg 12

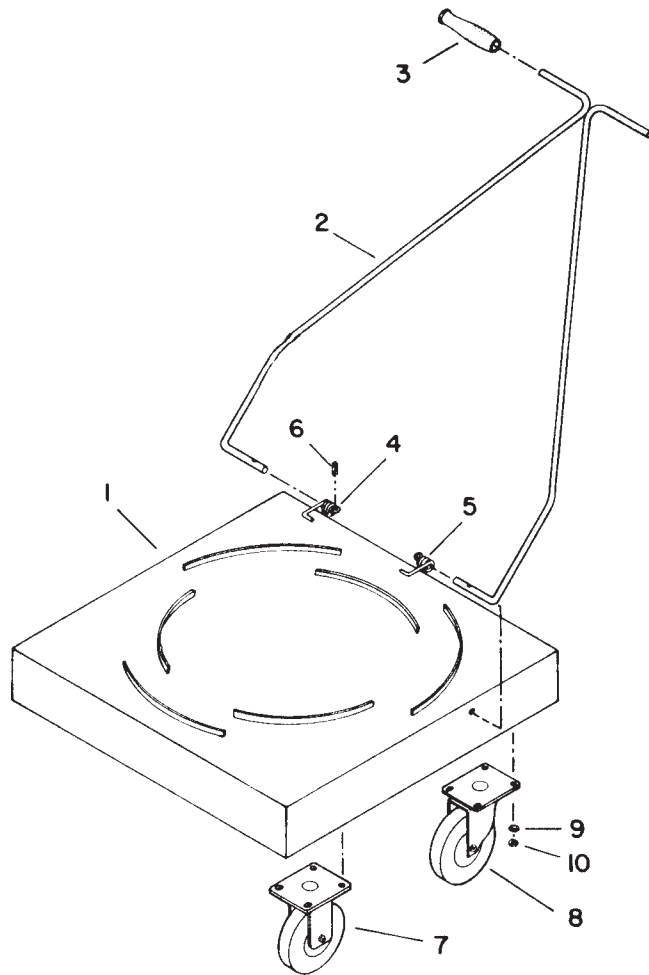

Parts Listings

ITEM NO.	PART NO.	QUANTITY	DESCRIPTION
1	750045	1	Weldment dolly 30/55
2	900051	1	Weldment, handle
3	900052	2	Grip, handle
4	900080	1	Spring, torsion RH
5	900081	1	Spring LH
6	711642	2	Rollpin
7	761050	2	Caster, rigid 5"
8	761049	2	Caster, swivel 5"
9	711545	16	WSR, helical Spr Loc 5/16
10	711319	16	Nut-Hex 5/16-18 ST PL
****	900048		Dolly cart complete

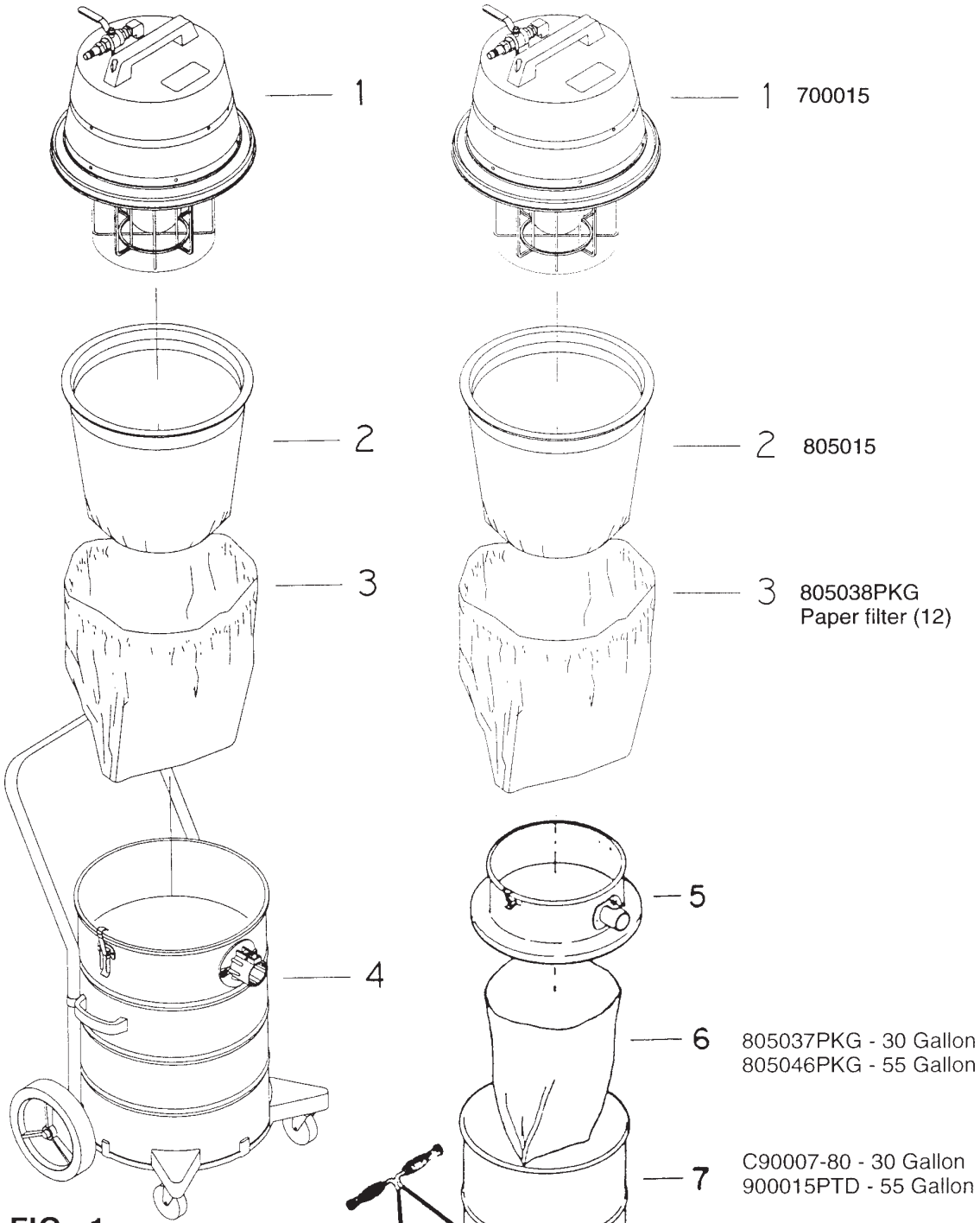

FIG. 1

FIG. 2

LIMITED WARRANTY

Minuteman International, Inc. warrants to the original purchaser/user that this product is free from defects in workmanship and materials under normal use and service for a period of three years from date of purchase. In addition, Minuteman International, Inc. will, at its option, honor labor warranty claims for the first 12 months from date of sale, provided such claims are submitted through and approved by factory authorized repair stations. Minuteman International, Inc. will, at its option, repair or replace without charge, except for transportation costs, parts that fail under normal use and service when operated and maintained in accordance with the applicable operation and instruction manuals.

This warranty does not apply to normal wear, or to items whose life is dependent on their use and care, such as belts, cords, switches, hoses, rubber parts, electrical motor components or adjustments. Parts not manufactured by Minuteman International, Inc. such as engines, batteries, battery chargers, hydraulic pumps, and tires are covered by and subject to the warranties and/or guarantees of their manufacturers. Please contact Minuteman International, Inc. for procedures in warranty claims against these manufacturers.

Special warning to purchaser — Use of replacement filters and/or prefilters not manufactured by Minuteman International, Inc. or its designated licensees, will void all warranties expressed or implied.

A potential health hazard exists without exact original equipment replacement.

All warranted items become the sole property of Minuteman International, Inc. or its original manufacturer, whichever the case may be.

Minuteman International, Inc. disclaims any implied warranty, including the warranty of merchantability and the warranty of fitness for a particular purpose. Minuteman International, Inc. assumes no responsibility for any special, incidental or consequential damages.

This limited warranty is applicable only in the U.S.A. and Canada, and is extended only to the original user/purchaser of this product. Customers outside the U.S.A. and Canada should contact their local distributor for export warranty policies. Minuteman International, Inc. is not responsible for costs or repairs performed by persons other than those specifically authorized by Minuteman International, Inc. This warranty does not apply to damage from transportation, alterations by unauthorized persons, misuse or abuse of the equipment, use of non-compatible chemicals, or damage to property, or loss of income due to malfunctions of the product.

If a difficulty develops with this machine, you should contact the dealer from whom it was purchased.

This warranty gives you specific legal rights, and you may have other rights which vary from state to state. Some states do not allow the exclusion or limitation of special, incidental or consequential damages, or limitations on how long an implied warranty lasts, so the above exclusions and limitations may not apply to you.

Minuteman[®]

World Headquarters
Minuteman International, Inc.
111 South Rohlwing Road
Addison, Illinois 60101

Minuteman Canada, Inc.
2210 Drew Road
Mississauga, Ontario
L5S 1B1

(630) 627-6900
FAX (630) 627-1130

(905) 673-3222
FAX (905) 673-5161

987725
Printed in U.S.A.